



## Sheet Metal Micrometers 158 Series



158-51-1

### FEATURES

- Graduation: .001" / 0.01mm
- Grey painted steel frame
- Carbide tipped measuring faces
- The dial reading allows for quick reading of sheet metal thickness
- Ratchet stop

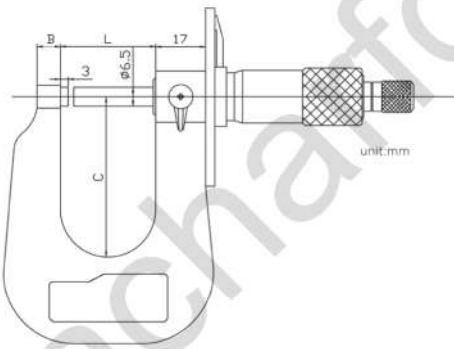

Flat	Spherical	Inch		Dimensions		
Code No.	Code No.	Range	Accuracy	L	B	C
158-51-1	158-51-3	0-6"	±.0001"	22mm	8mm	55mm
158-52-1	158-52-3	0-1"	±.0001"	32mm	8mm	55mm
158-53-1	158-53-3	1-2"	±.0002"	57mm	12mm	105mm

Flat	Spherical	Metric		Dimensions		
Code No.	Code No.	Range	Accuracy	L	B	C
158-51-0	158-51-2	0-15mm	0.004mm	22mm	8mm	55mm
158-52-0	158-52-2	0-25mm	0.004mm	32mm	8mm	55mm
158-53-0	158-53-2	0-50mm	0.005mm	57mm	12mm	105mm