



Deep Throat Micrometers

150 Series



150-51-0

FEATURES

- Graduation: .0001" / 0.01mm
- For measuring thickness of sheet metal paper and sheet plastic
- Carbide tipped measuring faces
- Grey painted steel frame
- Ratchet stop

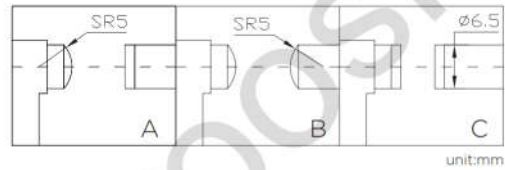
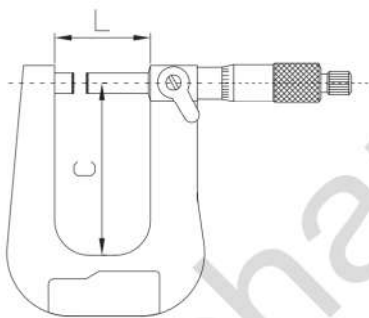

unit:mm

Anvil Type A	Anvil Type B	Anvil Type C	Inch			Dimensions	
Code No.	Code No.	Code No.	Throat Depth	Range	Accuracy	L	C
150-01-1	150-31-1	150-51-1	50mm	0-1"	±.0002"	32mm	55mm
150-02-1	150-32-1	150-52-1		1-2"	±.0002"	57mm	55mm
150-01-3	150-31-3	150-51-3	100mm	0-1"	±.0002"	32mm	105mm
150-02-3	150-32-3	150-52-3		1-2"	±.0002"	57mm	105mm
150-01-5	150-31-5	150-51-5	150mm	0-1"	±.0003"	32mm	155mm
150-02-5	150-32-5	150-52-5		1-2"	±.0003"	57mm	155mm
150-01-7	150-31-7	-	300mm	0-1"	±.0003"	32mm	310mm
150-02-7	150-32-7	-		1-2"	±.0003"	57mm	310mm

Anvil Type A	Anvil Type B	Anvil Type C	Metric			Dimensions	
Code No.	Code No.	Code No.	Throat Depth	Range	Accuracy	L	C
150-01-0	150-31-0	150-51-0	50mm	0-25mm	0.004mm	32mm	55mm
150-02-0	150-32-0	150-52-0		25-50mm	0.004mm	57mm	55mm
150-01-2	150-31-2	150-51-2	100mm	0-25mm	0.005mm	32mm	105mm
150-02-2	150-32-2	150-52-2		25-50mm	0.005mm	57mm	105mm
150-01-4	150-31-4	150-51-4	150mm	0-25mm	0.006mm	32mm	155mm
150-02-4	150-32-4	150-52-4		25-50mm	0.006mm	57mm	155mm
150-01-6	150-31-6	-	300mm	0-25mm	0.007mm	32mm	310mm
150-02-6	150-32-6	-		25-50mm	0.007mm	57mm	310mm