

Digital Three Point Internal Micrometers (100-300mm/4.0-12.0")

208 Series

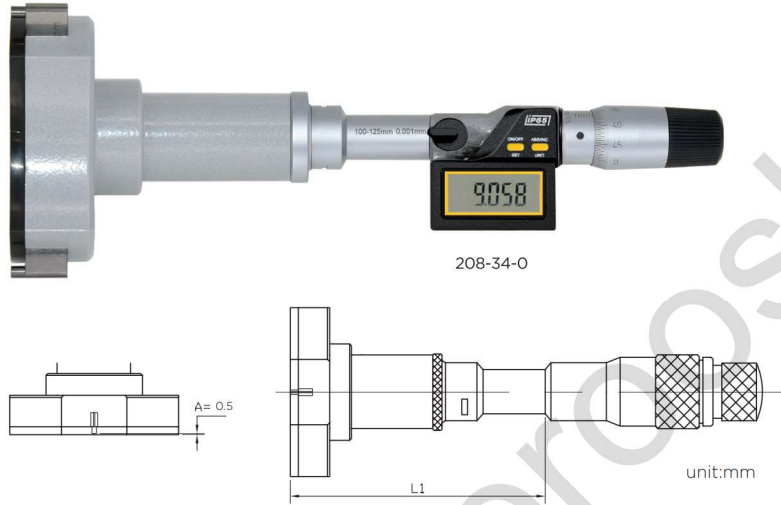

FEATURES

- Resolution: .00005" / 0.001mm
- Ratchet stop
- Measuring contact points are designed to allow measurements near to the bottom of blind holes
- Additional extensions can be added to increase the measuring depth
- Measuring surfaces are carbide
- Setting rings are not included with the set but are optional
- Support Bluetooth data transmission
Bluetooth data output: 901-01-5
- Protection level IP65



Inch			Optional	Dimensions	
Code No.	Range	Accuracy	Setting Ring	L1	Extension Rod
208-34-1	4-5"	±.0002"	4"	5.8"	6"
208-35-1	5-6"	±.0002"	5"	5.8"	6"
208-36-1	6-7"	±.0002"	6"	5.8"	6"
208-37-1	7-8"	±.0002"	7"	5.8"	6"
208-38-1	8-9"	±.00028"	8"	5.8"	6"
208-39-1	9-10"	±.00028"	9"	5.8"	6"
208-40-1	10-11"	±.00028"	10"	5.8"	6"
208-41-1	11-12"	±.00028"	11"	5.8"	6"

Metric			Optional	Dimensions	
Code No.	Range	Accuracy	Setting Ring	L1	Extension Rod
208-34-0	100-125mm	0.005mm	100mm	145mm	150mm
208-35-0	125-150mm	0.005mm	125mm	145mm	150mm
208-36-0	150-175mm	0.005mm	150mm	145mm	150mm
208-37-0	175-200mm	0.005mm	175mm	145mm	150mm
208-38-0	200-225mm	0.007mm	200mm	145mm	150mm
208-39-0	225-250mm	0.007mm	225mm	145mm	150mm
208-40-0	250-275mm	0.007mm	250mm	145mm	150mm
208-41-0	275-300mm	0.007mm	275mm	145mm	150mm