

PRECISION BORE GAGES

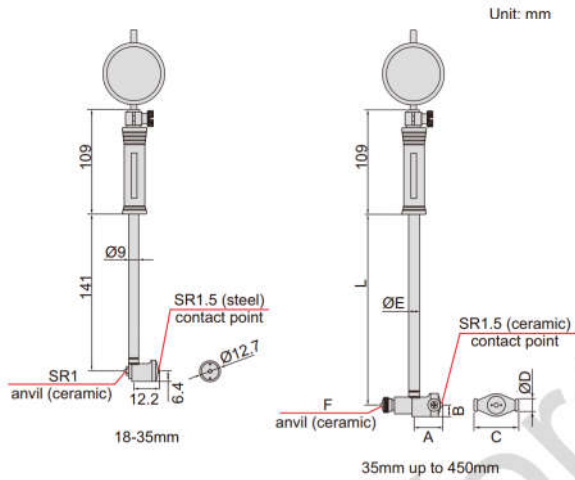

- Optional accessory: setting ring (code 6312), bore gage setter

| Range | A | B | C | ØD | ØE | F | L |
|-----------|------|----|-------|----|------|-------|-----|
| 35-60mm | 22 | 9 | 27 | 13 | 12.8 | SR2 | 141 |
| 50-100mm | 26 | 9 | 35 | 13 | 12.8 | SR2 | 141 |
| 50-160mm | 26 | 9 | 35 | 13 | 12.8 | SR2 | 141 |
| 100-160mm | 26 | 9 | 35 | 13 | 12.8 | SR2 | 141 |
| 160-250mm | 56.5 | 13 | 74.5 | 15 | 12.8 | SR2 | 241 |
| 250-450mm | 86.5 | 15 | 101.5 | 15 | 14.5 | SR2.5 | 241 |

With dial indicator

| Code | Range | Indicator | Accuracy | Repeatability |
|----------|-----------|---|----------|---------------|
| 2825-35 | 18-35mm | dial indicator, range 1mm, graduation 0.001mm (code 2313-1FA) | ±0.007mm | 0.0015mm |
| 2825-60 | 35-60mm | | ±0.007mm | 0.0015mm |
| 2825-100 | 50-100mm | | ±0.007mm | 0.0015mm |
| 2825-160 | 50-160mm | | ±0.007mm | 0.0015mm |
| 2825-161 | 100-160mm | | ±0.007mm | 0.0015mm |
| 2825-250 | 160-250mm | | ±0.007mm | 0.0015mm |
| 2825-450 | 250-450mm | | ±0.007mm | 0.0015mm |

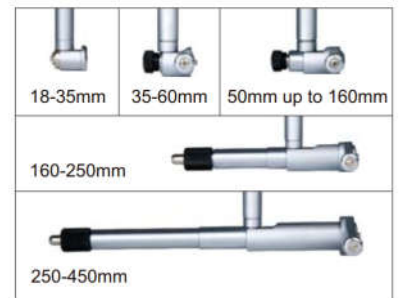

With digital indicator
(data output cable code 7315-50M page 5, 7302-40M page 13, optional)

| Code | Range | Indicator | Accuracy | Repeatability |
|----------|-----------|---|----------|---------------|
| 2126-35 | 18-35mm | digital indicator, code 2108-101F, range 12.7mm/0.5", resolution 0.001mm/0.00005" | ±0.007mm | 0.002mm |
| 2126-60 | 35-60mm | | ±0.007mm | 0.002mm |
| 2126-100 | 50-100mm | | ±0.007mm | 0.002mm |
| 2126-160 | 50-160mm | | ±0.007mm | 0.002mm |
| 2126-161 | 100-160mm | | ±0.007mm | 0.002mm |
| 2126-250 | 160-250mm | | ±0.007mm | 0.002mm |
| 2126-450 | 250-450mm | | ±0.007mm | 0.002mm |

