

Adjustable Wrench

3611

- Chrome vanadium alloy steel
- Polish, phosphate & chrome plated
- DIN 3117



3611R



3611HR



3611P



3611HP

KT NO.	mm	H1 mm	L mm		
3611-04R	14	4.3	109	91	12 / 108
3611-06R	20	7	150	136	12 / 108
3611-08R	25	8	200	245	12 / 48
3611-10R	30	11	250	415	10 / 60
3611-12R	35	13	300	713	5 / 40
3611-06P	20	7	150	127	12 / 108
3611-08P	25	8	200	246	12 / 48
3611-10P	30	11	250	415	10 / 60
3611-12P	35	13	300	691	5 / 40



KT NO.	mm	H1 mm	L mm		
3611-15HR	43	13	365	1351	1 / 20
3611-18HR	52	18	450	1877	1 / 6
3611-24HR	62	23	600	3720	1 / 6
3611-15HP	43	13	365	1348	1 / 20
3611-18HP	52	18	450	1750	1 / 6
3611-24HP	62	23	600	3669	1 / 6

Reversible Jaw Adjustable Wrench

3614-08R

- Chrome vanadium alloy steel
- Dual function wide jaws can be used as an adjustable wrench or pipe Wrench. On one side, the jaw is flat for traditional usage to avoid damaging the parts.
- On the other side, the jaw is finely serrated for powerful tightening on tubes and other parts requiring strong grip and high torque.
- Super wide jaw opening, 50% wider than regular adjustable wrenches
- Deep throat, 30% longer jaws than traditional adjustable wrenches
- Screw pin with front side metric or SAE scale
- 15°, perfectly matched knurl and teeth of jaw for smooth running
- TPR handle with end hole button

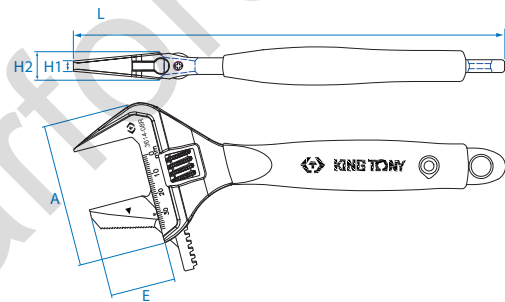
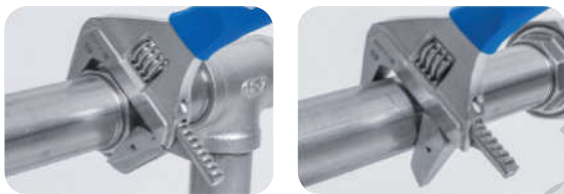

KT NO.	mm	A mm	E mm	H1 mm	H2 mm	L mm		
3614-08R	38	69	32.4	5.7	13.9	212	298.6	4 / 40

Ratcheting Adjustable Wrench

3631-10R

- Chrome vanadium alloy steel
- Magic button to switch ratchet function on/ off
- Wider jaw opening, comfortable & durability
- Excellent in each movement of knurl, tension enhanced and precise
- Patented, more than 130% of ASME standard



KT NO.	mm	Overall length mm		
3631-10R	32	257	470	6 / 36