

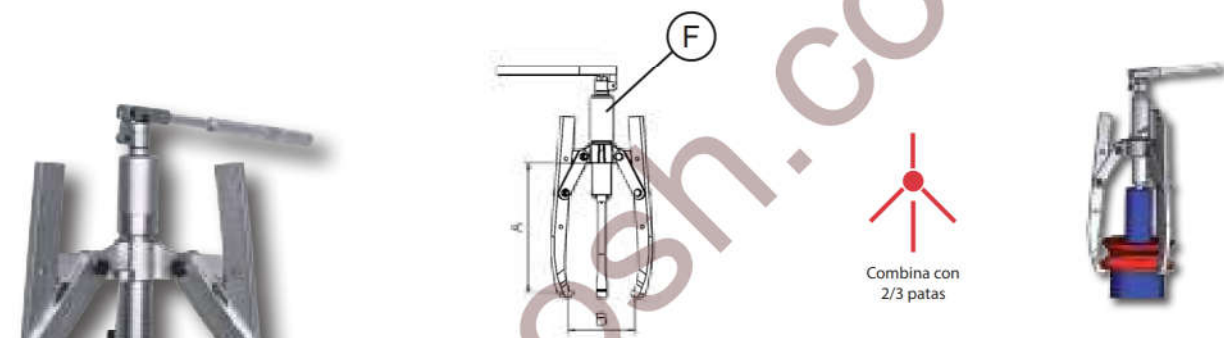







Extractor hidráulico con bomba y cilindro integrados Serie 1300CTH
Hydraulic ram puller

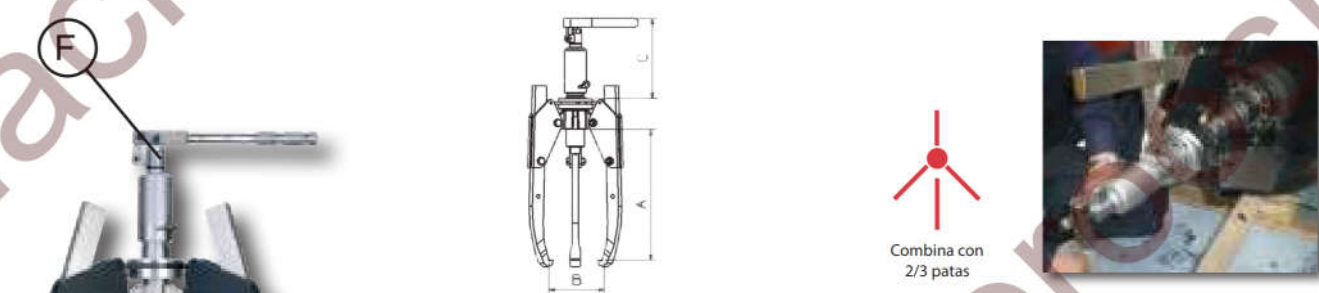

Ref.	€/u.	Tm.	A	B		carrera/ stroke		F	
1306CTH	560,90	6	300	310	✓	62	10,2	00806	131005
1306CLTH	572,60	6	380	360	✓	62	11,2	00806	131006
1306CXTH	620,00	6	460	410	✓	62	13,6	00806	131016
1308CTH	755,90	8	370	425	-	82	19,5	00808	131705
1308CLTH	802,70	8	485	480	-	82	21,5	00808	131706
1308CXTH	858,20	8	600	540	-	82	23,5	00808	131716

Extractor autocentrante hidráulico con bomba y cilindro integrados Serie 1300CTA
Self centering hydraulic ram puller



Ref.	€/u.	A	B max	B min	C		Tm.		F	
1306CTA	728,20	300	310	50	220	✓	6	14,5	00806	131005
1306CLTA	739,00	380	360	50	220	✓	6	15,0	00806	131006
1306CXTA	787,30	460	410	50	220	✓	6	16,0	00806	131016
1308CTA	967,70	370	425	70	205	-	8	19,5	00808	131705
1308CLTA	1.014,50	485	480	70	205	-	8	21,5	00808	131706
1308CXTA	1.070,00	600	540	70	205	-	8	23,5	00808	131716

Husillo hidráulico compacto / Hydraulic ram

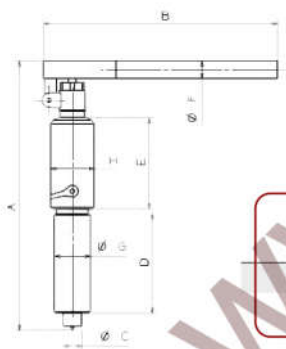

Ref.	€/u.	Tm.	carrera / stroke	A	B	ØC	D	E	ØF	ØG	ØH	
00806	305,00	6	62	340	310	23	120	115	22	45	54	3,1
00808	329,00	8	82	360	310	23	155	115	22	50	30	3,8