

Conjunto / Set

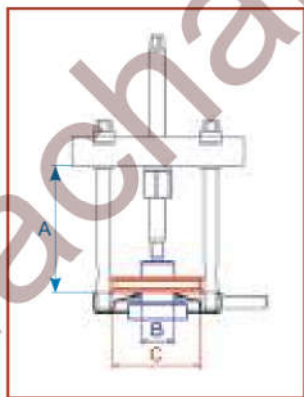

Los extractores 1100 combinan con la serie 1200.
Como medida de la polea a extraer no debe tomarse el mínimo de la guillotina cota B, sino la cota C que es la distancia entre alargaderas.

*Serie 1100 push pullers fit series 1200 (splitters).
The relevant measurement is the C (distance between extensions) not the B (pulley axle).*



B: Ø del eje. / Axe Ø.
C: Ø máx. de la pieza a extraer / Max. work piece.



Serie 1100 - 1200

Ref.	€/u.	A	B	C
1102 - 1202A	138,90	100	55	90
1103 - 1203A	166,30	100	80	130
1110 - 1204B	290,00	152	108	175
1120 - 1206B	573,00	220	134	230
1128 - 1208B	835,00	220	180	302
1135 - 1208C	1.403,70	418	180	285
1135 - 1210C	1.833,70	418	250	372
1150 - 1210D	2.549,00	617	250	362
1150 - 1212D	2.978,00	617	300	435
1150 - 1213D	4.015,00	617	300	450



Serie 1100S - 1200

Ref.	€/u.	A	B	C
1102S - 1202A	125,30	100	55	90
1103S - 1203A	152,70	100	80	130
1110S - 1204B	254,10	152	108	175
1110S - 1206B	377,30	152	77	182
1115S - 1206B	397,30	152	119	220
1120S - 1206B	543,40	220	134	230
1128S - 1206B	645,50	220	155	290
1128S - 1208B	808,50	220	180	302



Conjunto de extractores / Puller set



Puente + guillotina + patas *Push puller + splitter + jaws*



Ref.	€/u.	Contiene / Contains	⚖
C1102S	171,90	1102S + (2)100250 + 1202A	2,0
C1103S	205,50	1103S + (2)100260 + 1203A	3,0
C1110S	331,90	1110S + (2)101050 + 1204B	6,5
C1115S	486,70	1115S + (2)101060 + 1206B	11,0